

Valon 2100 21cm 1420 MHz to 20 MHz Downconverter Module

Specification and Operations Manual

Version 1.00

DEC 07 2016



www.valontechnology.com

1	Introduction	3
1.1	Overview	3
1.2	Detailed Description	3
1.3	Electrical Specifications.....	5
1.3.1	Power Requirements.....	5
1.3.2	Electrical Characteristics.....	5
1.4	Mechanical Dimensions	6
1.5	Power Connections.....	6
1.6	Local Oscillator Connections	
1.7	RoHS (Restriction of the use of certain Hazardous Substances)	7
1.8	FCC Part 15.....	7
1.9	Place of Manufacture.....	7
2	Quick-Start Instructions	8
3	Applications	9
3.1	Typical setup using AFEDri SDR.....	9
3.2	Small Interferometer Example.....	10

1 Introduction

1.1 Overview

The **Valon 2100 Downconverter**, when combined with a **Valon 5009 Dual Frequency synthesizer module**, provides a high-performance, compact receiver downconverter system. Applications include hydrogen line studies at 1420MHz and radio astronomy in the protected 30MHz segment of the 21 cm band. The 2100 is specifically designed to interface to direct sampling receivers, SDRs, and data acquisition systems operating 10MHz~30MHz range. Receivers having noise figures as high as 12dB can be used directly without impacting the overall system noise figure.

1.2 Detailed Description

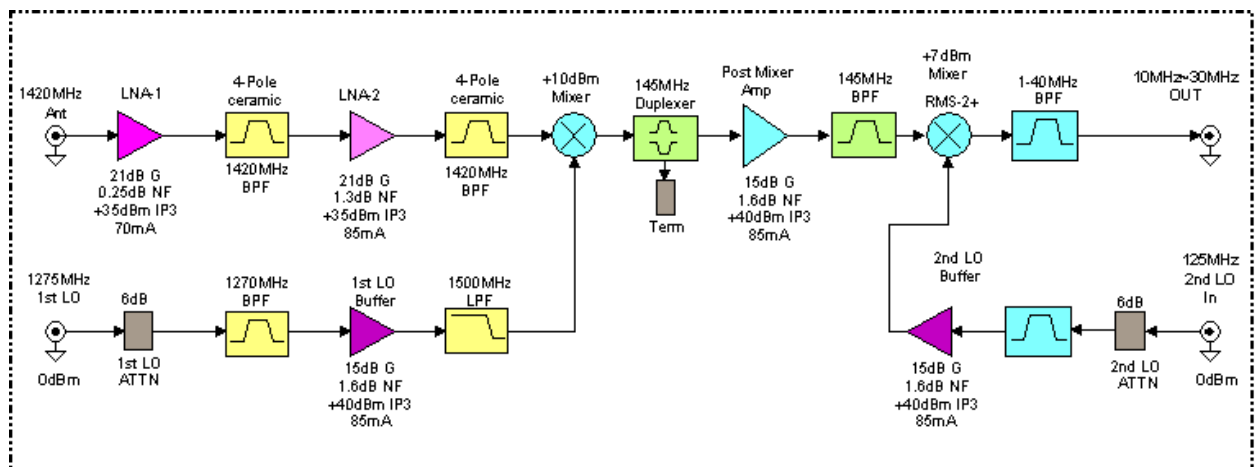

Figure 1 Block Diagram

The block diagram of the 2100 Downconverter is shown in **Figure 1**. The downconverter utilizes a dual conversion topology with a first IF centered at 145MHz and a second IF centered at 15MHz. The first LO requires an input at 1275MHz at 0dBm. The second LO requires an input at 125MHz at 0dBm.

The RF input is applied directly to the first stage very low noise amplifier (VLNA). This 20dB amplifier has a very high IP3 and does not require an input filter when connected directly to a 1420MHz antenna feed. The output of the first stage VLNA is filtered by the 4-pole ceramic filter with a 90MHz 3dB bandwidth. The second stage low noise amplifier (LNA) provides an additional 20dB gain and is followed by another similar 4-pole ceramic filter. This second filter provides additional RF preselection filtering as well as rejecting image signals and noise. The combined nearly 40+dB RF gain ensure the system maintains a very low noise figure.

The first conversion is provided by a high-dynamic range Level-10 passive double balance mixer. The first mixer converts the 1420MHz RF input signal to a 145MHz first IF frequency using an external LO at 1275MHz. The external 1st LO signal is bandpass filtered to remove harmonics and spurious signals and amplified to provide the required +10dBm LO injection power.

The IF output from the 1st mixer is applied to a duplexer which terminates any LO feedthrough signal while passing the 1st IF frequencies around 145MHz. The post mixer IF amplifier provides additional system gain while preserving the overall system noise figure. The output of the post mixer amplifier is applied to the 1st IF LC bandpass filter. This filter removes any 1st LO feedthrough signal as well as providing a channel filter with approximately 30MHz bandwidth.

The output from the 1st IF bandpass filter is applied to the second mixer which converts the 145MHz IF to the 10MHz~30MHz second IF. The second mixer is a level-7 mixer and requires an external LO signal at 125MHz. The external 2nd LO signal at 0dBm is bandpass filtered and amplified before being applied to the 2nd mixer at 7dBm. The 2nd IF output from the second mixer is bandpass filtered to 1MHz~40MHz to remove the 2nd LO feedthrough signal as well as other out of band signals that may be present.

1.3 Electrical Specifications

1.3.1 Power Requirements

Parameter	Min.	Nominal	Max.	Units
Input Voltage	5.5	6	9	V
Safe temporary input	-20		+20	V
Input Current		400		mA

1.3.2 Electrical Characteristics

Parameter	Min.	typical	Max.	Units	Notes
Conversion gain					
1410~1430 MHz	40	42	43	dB	
1380~1450 MHz	37			dB	
Noise Figure					
1410~1430 MHz		0.4	0.55	dB	Case temperature 20°C
Noise Temp.					
1410~1430 MHz		30	40	K	Case temperature 20°C
Preselection Filter BW		90		MHz	-3dB bandwidth at 1420MHz
Image rejection	90			dB	1128MHz
Input impedance		50		Ω	Nominal
Return Loss	12	14		dB	1410 MHz to 1420 MHz
Return Loss	6	8		dB	1400 MHz to 1450 MHz
Input IP3 (in-band)		-36		dBm	Two tone 1420 MHz 1421 MHz
Input P1dB (in-band)		-45		dBm	1dB gain compression
Input IP3 (out of band)		+35		dBm	
Input P1dB (out of band)		+18		dBm	
Maximum safe input			13	dBm	
Output Frequency	5	20	35	MHz	
Output Impedance		50		Ω	Nominal
Return Loss		>12		dB	5 MHz to 35 MHz
1 st LO recommended		1275		MHz	0dBm
2 nd LO recommended		125		MHz	0dBm
1 st LO Leakage at RF Input		-122	<-120	dBm	
2 nd LO Leakage at RF Input		-130	<-125	dBm	

1.4 Mechanical Dimensions

All dimensions are in inches.

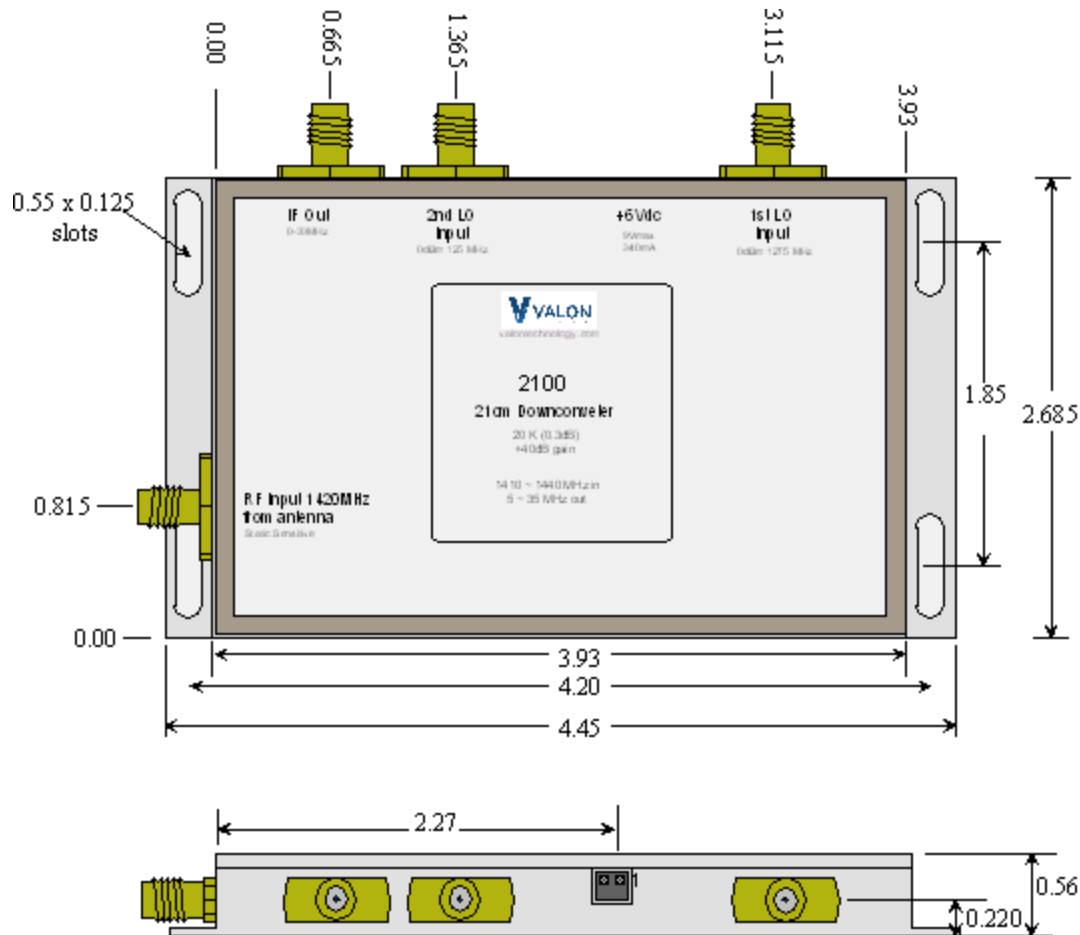

Figure 2 2100 module housing dimensions and mounting details.

All RF connectors are SMA female. Power entry connector is 2mm Hirose.

1.5 DC Power Connections.

Power connections are made to the dc power supply using the supplied Hirose 2-pin plug and 24" pig-tail cable assembly supplied. The optimum input voltage for full performance is 6 Volts at ~410mA maximum. The red wire is the positive input and correct polarity is required. The 2100 is reverse polarity protected and no damage will occur if reverse connected to dc power supplies of less than 15V. The 2100 module is intended to share the same power supply as the 5009 synthesizer module.

1.6 Local Oscillator Connections

The downconverter requires two local oscillator signals, one at 1275MHz for the first LO and the other at 125MHz for the second LO. The Valon 5009 Dual Frequency synthesizer can provide these two signals, however any signal generator that meets the requirements for the LO signals can be used. The nominal input level is 0dBm. The RF input frequency is related to the IF output by:

$F_{in} = F_{if} + F_{1stLO} + f_{2ndLO}$. Where F_{in} is the input RF frequency, F_{1stLO} is the first LO frequency (typically 1275MHz), F_{2ndLO} is the second LO frequency (typically 125MHz).

Example: $f_{1stLO} = 1275\text{MHz}$, $f_{2ndLO} = 125\text{MHz}$, $f_{if} = 20\text{MHz}$ = $1275 + 125 + 20 = 1420\text{MHz}$.

This example will allow the user to tune 1410MHz to 1430MHz with the IF receiver. If other portions of the band are desired then the 1st LO may be set higher or lower by up to 40MHz.

The mechanical arrangement of the SMA connectors on the 2100 downconverter matches the connector spacing on the 5009 such that only SMA Male-Male barrel adapters are need to directly connect these two units. A more flexible mounting solution may be had by using flexible cables. Any length and type SMA cable can be used so long as the signal at the 2100 LO input is at 0dBm.

1.7 RoHS (Restriction of the use of certain Hazardous Substances)

The 2100 module is manufactured using all RoHS compliant components and RoHS compliant printed circuit board processing. The case is manufactured using only aluminum with steel fasteners.

Valon Technology, LLC certifies that the 2100 is RoHS compliant and conforms with the requirements of EC directive 2002/95/EC (RoHS) by having no intentional addition of Lead (Pb), Cadmium (Cd), Mercury (Hg), Hexavalent Chromium (Cr), Polybrominated Biphenyls (PBB), Polybrominated Diphenyl Ethers (PBDE), and any trace impurities of these substances are below the threshold limits as specified by the RoHS directive, specifically Cr+6, Hg, Pb, PBB, PBDE do not exceed 1000 ppm (0.1%) and Cd does not exceed 100 ppm (0.01%).

1.8 FCC Part 15

The 2100 is considered an industrial component and is intended to be incorporated into customer supplied equipment and is therefore exempt from FCC Part 15.

1.9 Place of Manufacture

The Valon 2100 printed circuit boards are fabricated and assembled in Northern California. All components are sourced from U.S.A. vendors and distributors. Final assembly and test is performed at Valon Technology.

2 Quick-Start Instructions

The 2100 Downconverter module requires no special preparation and is ready to use. Just apply 6Vdc @ ~410mA using the supplied power cable (red +, black -). When power is applied and within the correct voltage range, a green LED will be visible shining through the label near the 2nd LO port.

2.1 User Supplied Local Oscillators:

Two local oscillators are required. Apply 1275MHz to the 1st LO input port and 125MHz to the 2nd LO port. The LO power should be set to 0dBm. Connect the receiver to the IF output port.

2.2 Valon 5009 Local Oscillator:

In order to program your desired frequencies or change any other settings you will need to download the **Configuration Manager** graphical user interface (GUI) program at: <http://valontechnology.com/5009users/5009.htm>. You should also download the Operations Manual at the same site location.

2.2.1 Step 1: Power Supply Connection

You are going to need a 6Vdc $\pm 0.5V$ at 600mA power supply. Use the supplied red-black Hirose cable to connect to your power supply. Connect it and you should see two blue LEDs illuminating through the label just below the Source 1 and Source 2 label markings. Your 5009 will now be set to 2440MHz on Source 1 and 2480MHz on Source 2.

2.2.2 Step 2: USB connection

Connect the provided USB cable to your 5009 and host computer. Your computer should recognize it as a new FTDI Virtual Com Port. If you have trouble, then it is likely you do not have the correct VCP (virtual com port) driver. (Download FTDI CDM v2.12.00 WHQL Certified.zip from the link below, unzip and run).

2.2.3 Step 3: Terminal Program

You will need a terminal program to change your 5009 settings. Just about any terminal program will work. We have provided **5009term.zip**. Unzip and running 5009term.exe will automatically find the correct Virtual Com Port. If you use a different terminal program, your port settings are 9600, 8, None, 1, None.

2.2.4 Step 4: Synthesizer Settings

If you ordered the 5009 with the 2100 the synthesizer will be ready to go with Source 1 set to 1275MHz and Source 2 set to 125MHz. Both will be set to an attenuation level of 15 which will provide the necessary 0dBm output.

Consult the **Valon 5009 Operations Manual** for more information on the use of these commands.

For the latest 5009 Downloads: <http://www.valontechnology.com/5009users/5009.htm>

3 Applications

3.1 Typical setup.

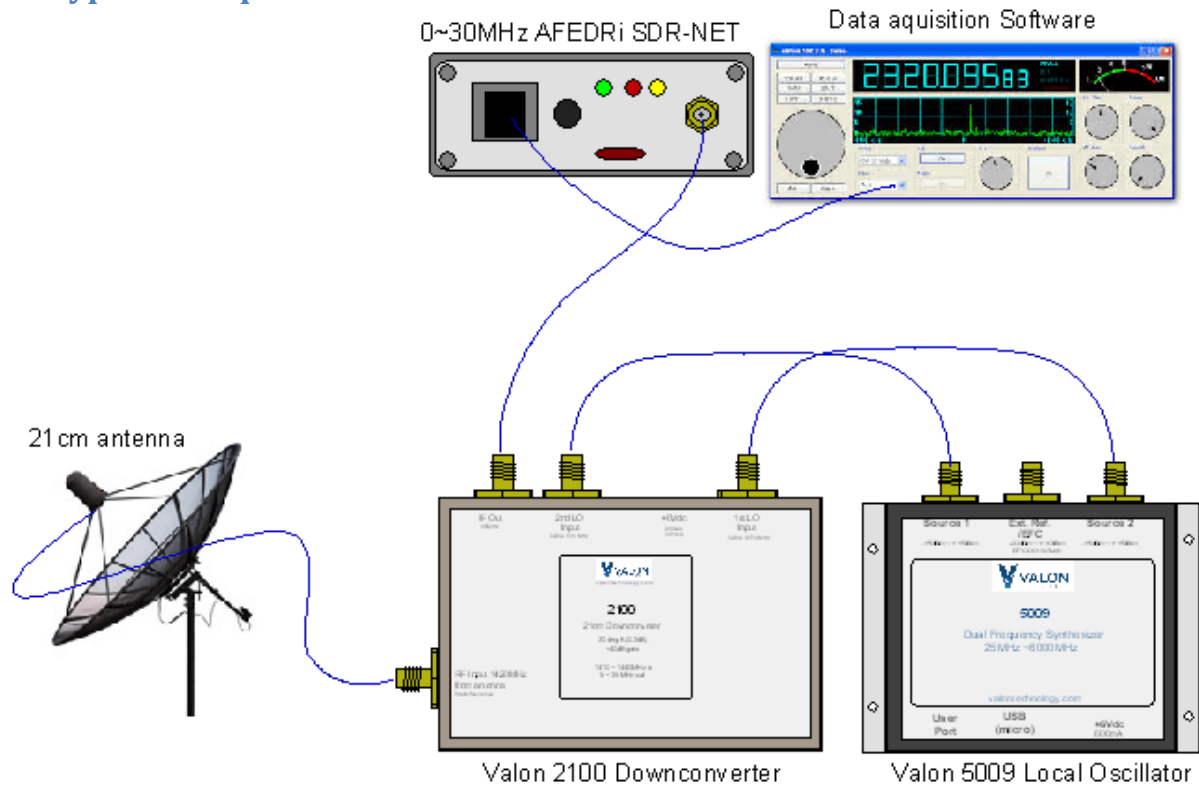

Figure 3 Typical downconverter connections using a Valon 5009 Dual Frequency Synthesizer.

Figure 3 above shows a typical setup. The 2100 downconverter and 5009 LO source should be placed at the antenna feed point. The illustration indicated a cabled connection to the antenna feed but this should be as short as possible and preferably just an adapter. Any receiver capable of tuning the IF frequencies from 10MHz to 30MHz can be used along with the appropriate post processing software. This example shows the AFEDRi SDR-NET receiver.

The IF connection can be as long a practically necessary. The downconverter will supply sufficient gain to mask the noise figure of any receiver with a noise figure up to 12dB. Noise figures worse than that will have some effect of the overall system noise figure and should be evaluated. The AFEDRi SDR has ~11dB noise figure and can be connected directly to the converter output. Most direct sampling receivers or simple ADC will have a noise figure of approximately 30dB and will require an additional 20dB IF amplifier.

The Figure 3 illustration shows only one 2100 downconverter being used with the antenna but two 2100 downconverters could be used with antenna feeds that provide both horizontal and vertical polarization probes. Only one 5009 or user LO set would be required so long the as the appropriate power splitters were used. The the two polarization signals could be combined in baseband to provide both linear polarizations as well as circular polarization.

3.2 Small Interferometer Example

A very small interferometer array (VSIA) can be configured using the setup shown below.

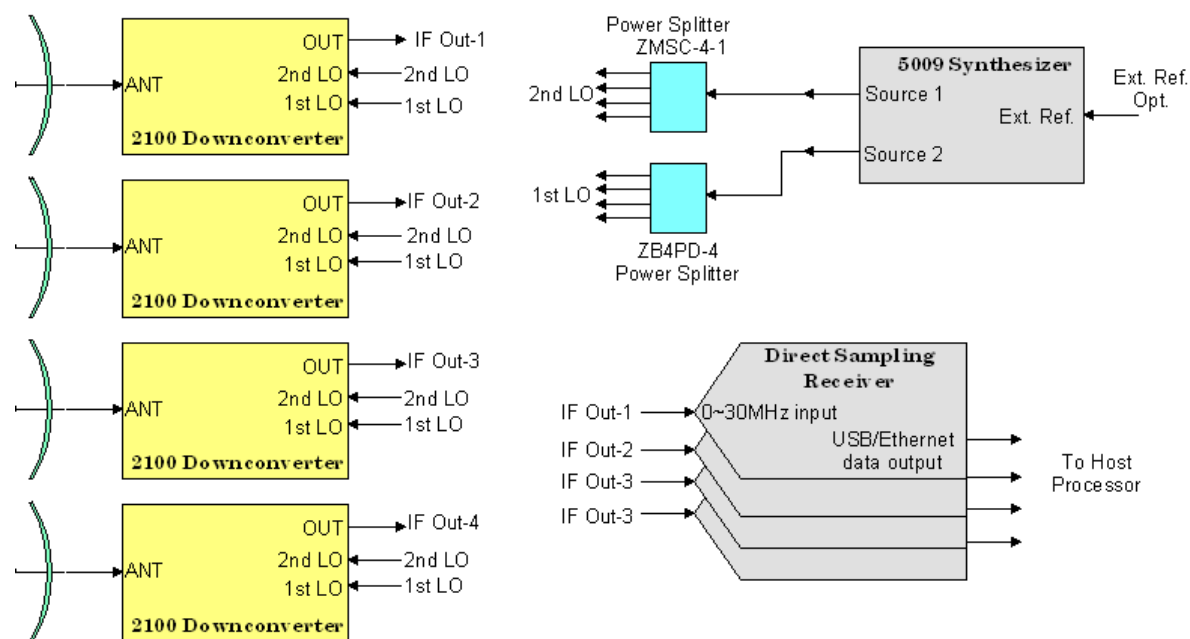

Figure 4 Small radio astronomy interferometer

This small array can be constructed using four small C-band parabolic dishes and four 2100 downconverters. Only one synthesizer module is required to supply phase coherent 1st and 2nd local oscillator signals to all four downconverter modules. The four-to-one power splitters are used to distribute the two local oscillators to all four downconverters in this example. The 5009 can supply up to +15dBm but the downconverters require only 0dBm so a 16-way power splitter could be used with up to 16 downconverters.

This system requires one 0MHz~30MHz direct sampling receiver (DSR) for each downconverter such as the AFEDRi SDR. These are low-cost DSRs and are easily interfaced to a host computer through USB or Ethernet. The AFEDRi has a noise figure of 11dB and can be used directly with no additional amplifiers or filters required.

A multichannel data acquisition module such as a 4-channel PicoScope 3403D could be used as the DSR. Typically these will not have enough sensitivity as their noise figures will be too high for direct connection to the downconverter output. However, an additional low-frequency amplifier with 20dB gain and 5dB noise figure would be all that is needed to use these types of DSRs.